



1995 - 2004
2RZFE (2.4 L) and 3RZFE (2.7 L)

Part Number:
7015190 1995-1999 8 Port High Boost
7015200 \$" "Ž" &&Baf: [YZ 4aaef

Kit Contents

Item #	Quantity	Description
1	1	Supercharger Assembly
2	1	Idler Pulley Assembly
3	1	Drive Belt
4	1	Fitting Instructions
5	1	Support Bracket Assembly
6	1	Hose Kits

Optional Supercharger Pulleys

1016158	58 mm 10 PSI pulley
1016160	60 mm 8 PSI pulley
1016162	62 mm 7 PSI pulley
1016165	65 mm 6 PSI pulley
1016168	68 mm 5 PSI pulley
1016170)" _ _ &BE; bg^W

**NOTE: Boost numbers are approximate and will change with engine components installed.*

Do not allow blower unit to exceed 14,000 RPMs.

Recommended:

Basic Tools:

- Basic Mechanics tools
- Metric Socket, Allen & Open-End Wrench Sets
- Masking Tape for Labeling Hardware and Parts
- Electrical Tape
- A Clean Work Bench
- A Parts Tray
- Rags or Shop Towels
- Teflon Tape
- Red Locktight

Safety Tools:

- Safety Goggles

Special Tools:

- Toyota Repair Manual

Accessories: (not included in the kit)

- Boost gauge recommended
- Spark plugs
- AFR Gauge
- Electric cooling fan
- Header, High flow Cat, Cat back Exhaust System



Section I - Installation Preparation

1. Before you begin, we recommend that you thoroughly clean the engine and engine compartment. If you don't, grease buildup on parts could become dislodged during the procedure and fall into the engine.
2. Make sure the engine has cooled fully before beginning this installation.
3. To help you later draw a diagram of your engine's vacuum hose routing before you disconnect anything. However, some of the vacuum connections on your intake manifold may not be the same as those on the supercharger. Study and closely follow the vacuum diagrams for your specific application included in the back pages of these instructions.
4. The LCE supercharger kit has been designed to reuse most of the stock nuts and bolts. Therefore, as you remove them, keep them with their components or label them for location. This will assure a faster, easier installation.
 - A. Removal of Stock Air Inlet System and Intake Manifold

1. Disconnect the ground cable from the battery, and then the positive cable. Remove battery from the vehicle.
2. Remove air cleaner hose with resonator. Figure 1
3. Remove evaporative canister vacuum switched valve (VSV) hose.
4. Remove PCV hose.

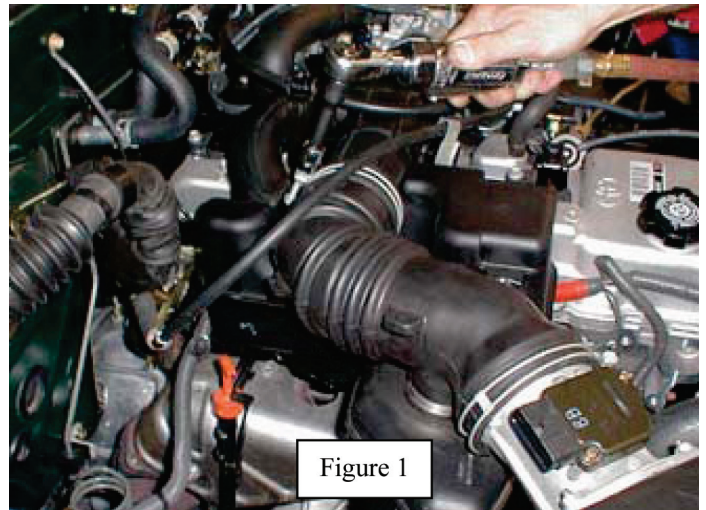

5. Remove EGR modulator and hoses. Note hose location and routing for re-installation. Figure 2

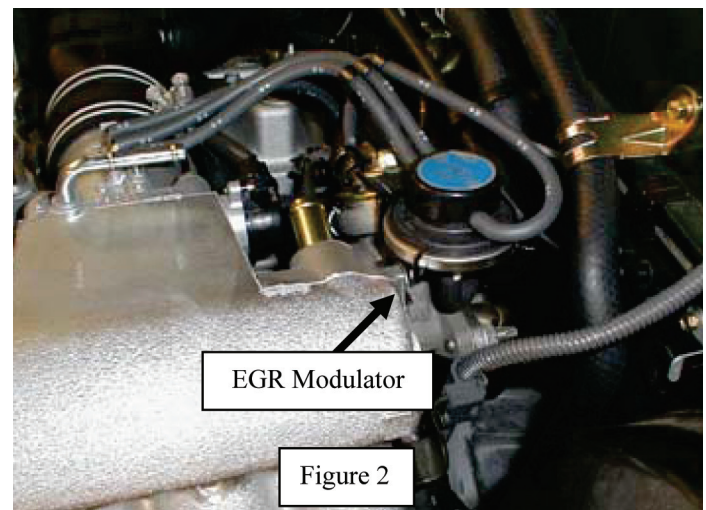

6. Disconnect power steering idle-up connector from the sensor and also the wiring from the intake manifold bracket. See arrows in Figure 3

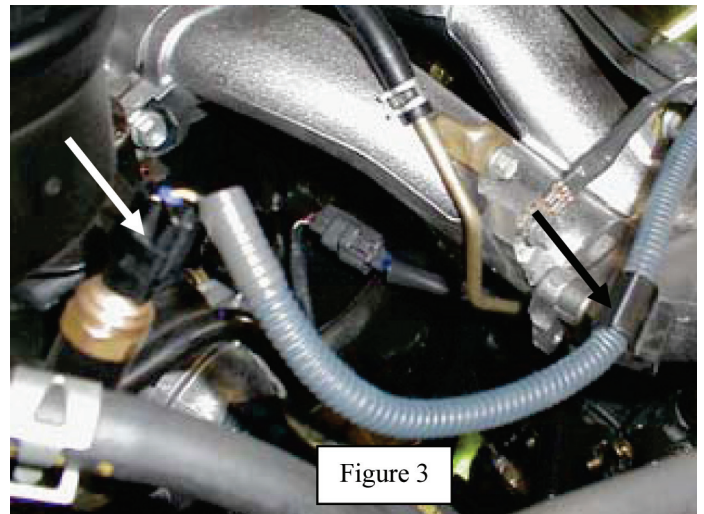

7. Remove fuel pressure regulator hose from intake air connector.
8. Remove intake air connector. Figure 4

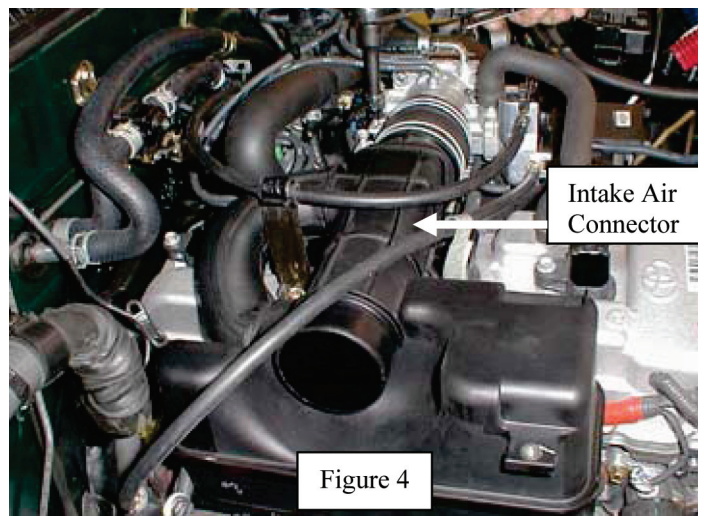

9. Disconnect Throttle Position Sensor (TPS) connector from TPS in throttle body.
10. Disconnect Idle Air Control (IAC) connector from IAC in throttle body. Disconnect coolant line from IAC. Pinch off coolant lines before EGR valve.
11. If vehicle is equipped with EGR, then disconnect EGR connector from EGR sensor in intake chamber. Note: If no EGR go to step 15
12. Remove throttle body from intake manifold and set aside. Figure 5

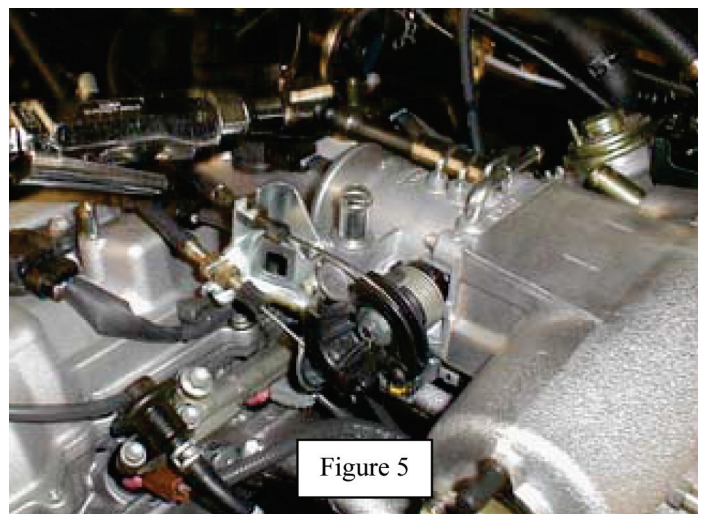

13. Disconnect EGR feed tube at EGR valve. See "A" arrows in Figure 6.
14. Disconnect EGR valve from intake chamber.
15. Remove wire harness bracket from backside of intake chamber. See arrow "B" in Figure 6. Remove bracket from wire harness.

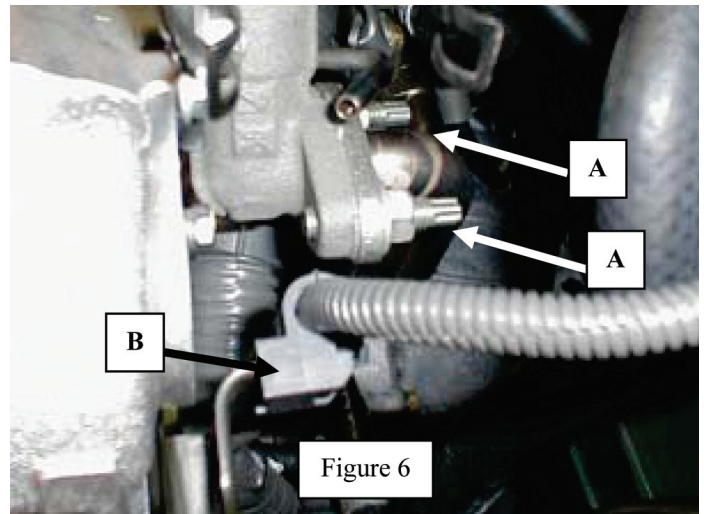

Figure 6

16. Remove bolt from the upper side of the intake chamber bracket see arrow in Figure 7. Loosen lower bolt from air intake chamber bracket.
17. Disconnect the DLC 1 from the bracket on the air intake chamber assembly. Note:1995-2001 vehicles only.
18. Remove the wire harness bracket for the DLC 1 wiring from the air intake chamber assembly. 1995-2001 vehicles only.

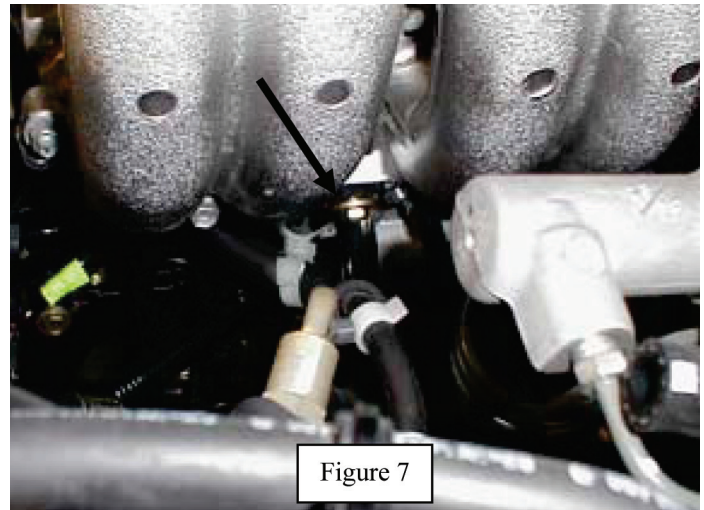

Figure 7

19. Disconnect the brake booster vacuum hose from the intake chamber hose barb.
20. If your vehicle is equipped with EGR, then disconnect EGR tube bracket from the backside of the cylinder head
21. Remove the 3 bolts and 2 nuts shown in Figure 8.
22. Remove the air intake chamber and gasket. On vehicles with EGR.
23. Remove the injector wiring ground strap from the intake manifold.

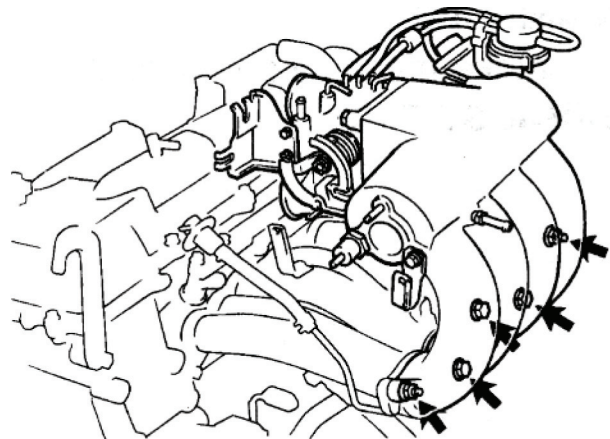

Figure 8

24. Remove the 2 bolts from the fuel return pipe and disconnect the fuel return hose from fuel pressure regulator. See Figure 9. Caution: Plug fuel return hose so that no fuel will spill. Set pipe and hose aside.
25. Remove fuel pressure regulator form the fuel rail.

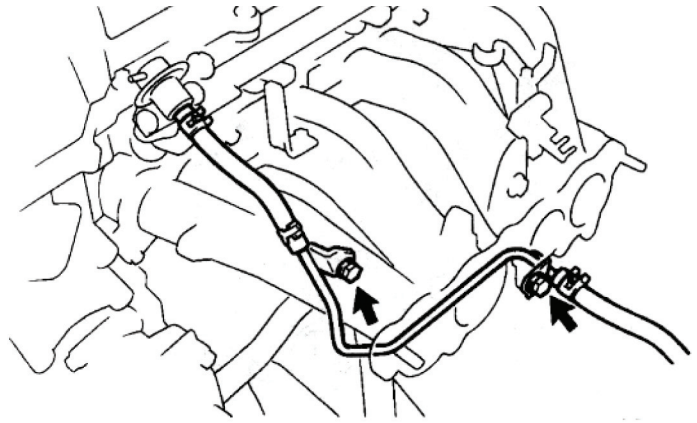

Figure 9

25. Disconnect wire loom clips from the intake manifold brackets and remove the clips from the wire loom. See arrows in Figure 10.
26. On vehicles with EGR, remove the EGR vacuum switched valve bracket from the intake manifold.
27. Disconnect the camshaft position sensor connector. If equipped See Figure 10.

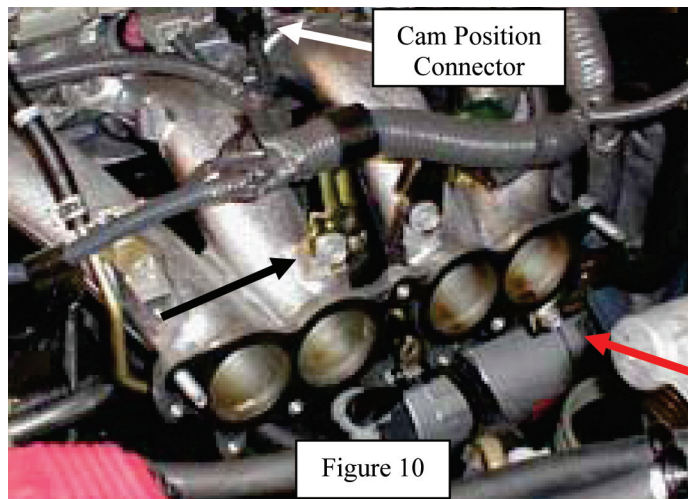

Figure 10

28. Remove wire-loom bracket and clips from the wire loom that was disconnected in Step 15.
29. Disconnect the detonation sensor connector (A), and the crankshaft position sensor connector (B). See Figure 11. Both connectors are located next to the engine block, and below the intake manifold.
30. Disconnect all four fuel injection connectors and set wiring aside.
31. On vehicles with EGR, remove the EGR coolant hose. Remove only the hose that runs down through the intake manifold runners. Plug hose so that coolant will not leak.

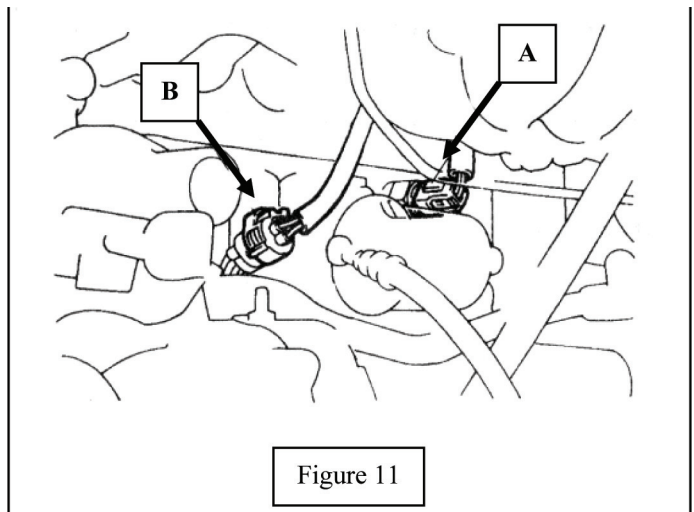

Figure 11

32. Disconnect the fuel inlet banjo fitting from the fuel rail. Remove both banjo washers. See Figure 12.

33. Remove the intake manifold from the cylinder head. You will replace the gasket with the new one in the kit.

34. Remove the original equipment (OE) intake manifold chamber stay.

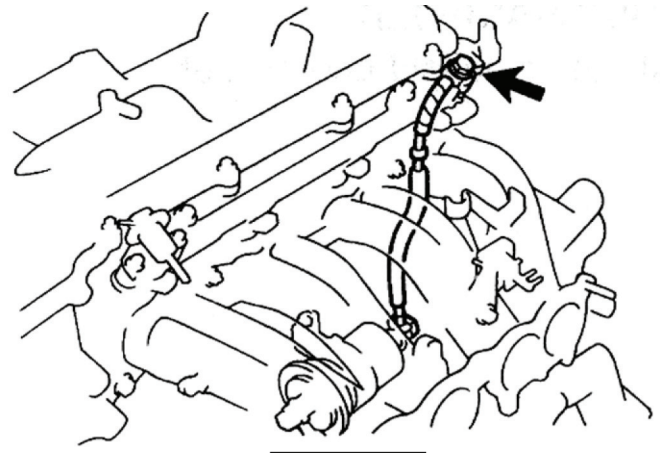

Figure 12

35. Remove the evaporative canister steel line that is secured to the top of the radiator fan shroud and set aside.

36. On 2000 and earlier model years, step 36 may not be necessary. Check the power steering pressure feed hose clearance to the supercharger by installing the supercharger main assembly onto the cylinder head.

When installing the supercharger, the supercharger drive pulley and snout slides under the power steering pump return hose. If necessary, adjust the power steering line next to the banjo fitting on the power steering pump.

See Figure 13. The steel line needs to be parallel with the engine centerline. Caution: Adjust carefully so the steel line will not kink. When adjusted correctly, the rubber hose that is connected to the steel line will have clearance to the supercharger housing and also to the lower radiator hose check and remove.

37. Attach the new supplied 2-piece lower manifold bracket to the engine mount with one 8mm x 25mm long flange head hex bolt See arrow in Figure 14.

Make sure the L-portion of the bracket is towards, the, front of the vehicle. Figure 14 shows the chamber stay in the assembled position. Attach only the lower bolt in this step. Tighten bolt finger tight.

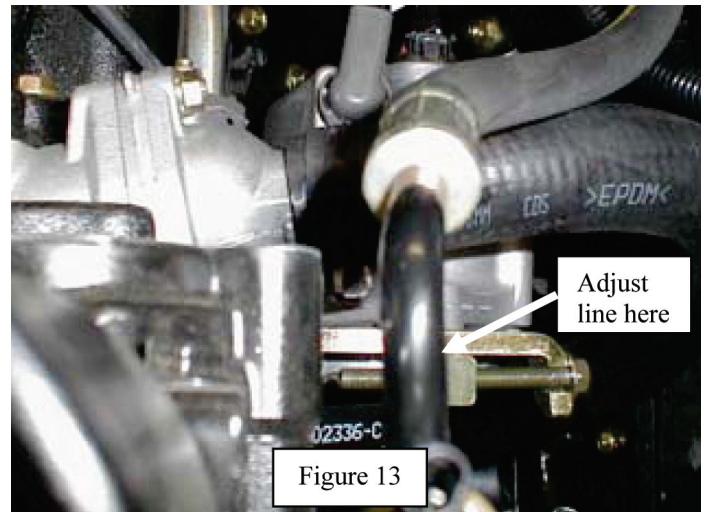

Figure 13

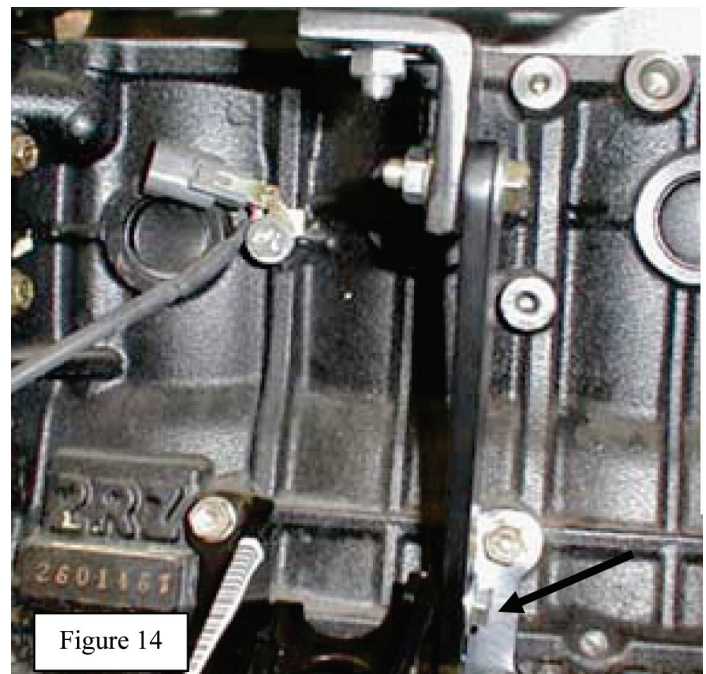
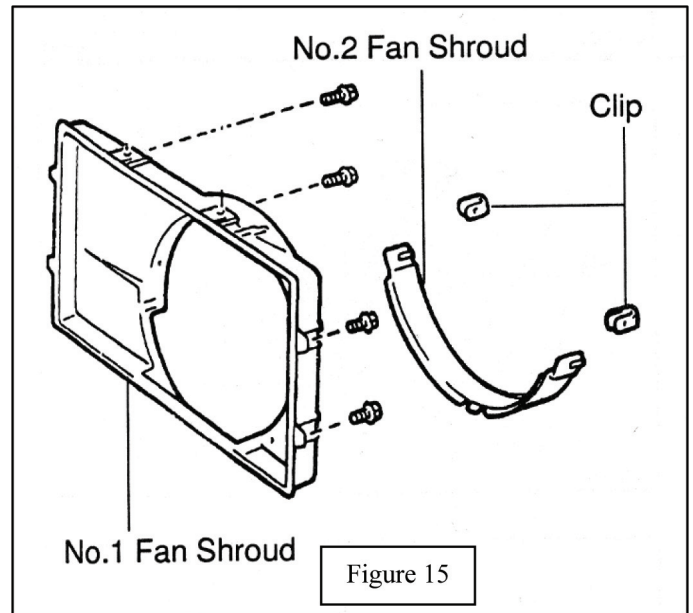
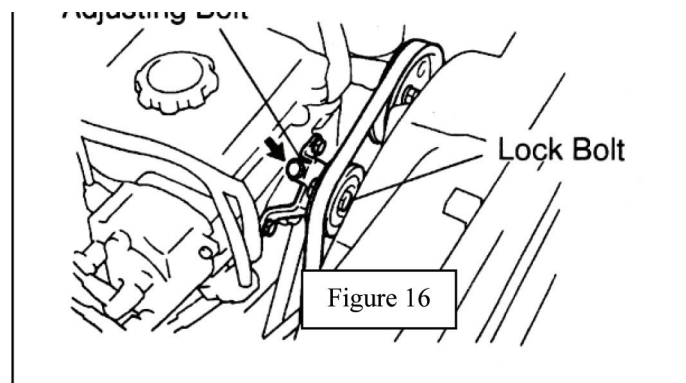

Figure 14

38. Remove the radiator fan shroud for easier access to the components in the following steps. See Figure 15.



39. Remove power steering belt. See Figure 16



40. Remove the two bolts that secure the power steering pump to the pump bracket. See Figure 18. power steering pulley dose not have to be removed access to the bolts is provided though the pulley holes.

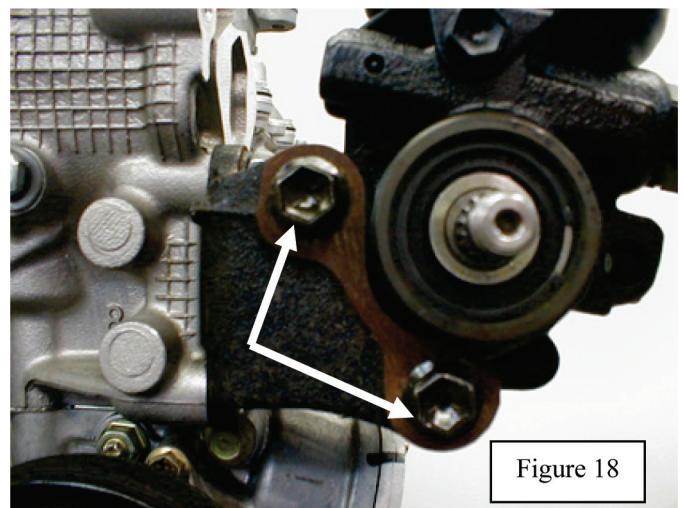

41. Install the supplied idler pulley bracket to the front of the power steering pump. See Figure 19. Note pulley is removed for photos only. Use (2) 10mm x 1.25 x 100mm long bolts supplied. Both bolts replace the OE bolts removed in Step 40. Torque bolts to 39 29 ft-lbs

Note: The idler pulley for the 3RZ should use the top hole. The 2RZ uses the lower hole

42. If your vehicle has eight round intake ports in the cylinder head, then proceed with steps 43 and 44.

Note: If your vehicle has four oval intake ports, then skip ahead to step 45.

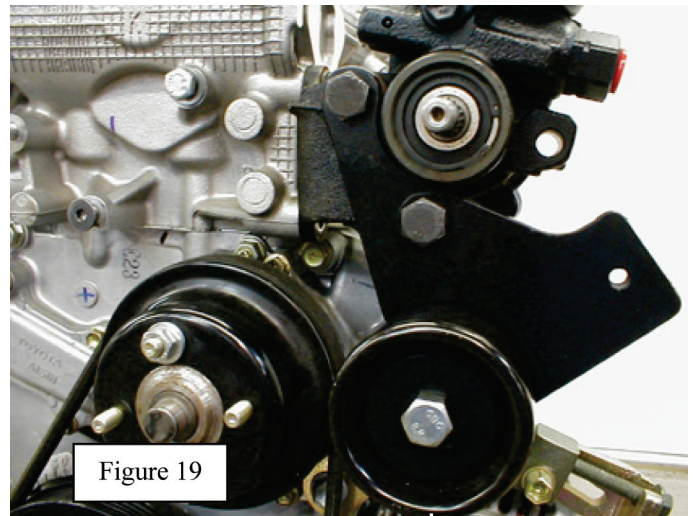

43. The wires that connect to both the detonation sensor and the crankshaft position sensor need to be routed below the intake manifold. Remove the nylon split flexible tubing around the area where the wires join the main engine wire loom. See Figure 23. Separate the detonation sensor and crankshaft position sensor wires back about 6" to 8" from the original breakout point. Use electrical tape to wrap the wires that have been split out from the main wire loom. Re-install the nylon split tubing around the main wire loom. Use electrical tape to secure the flexible tubing.

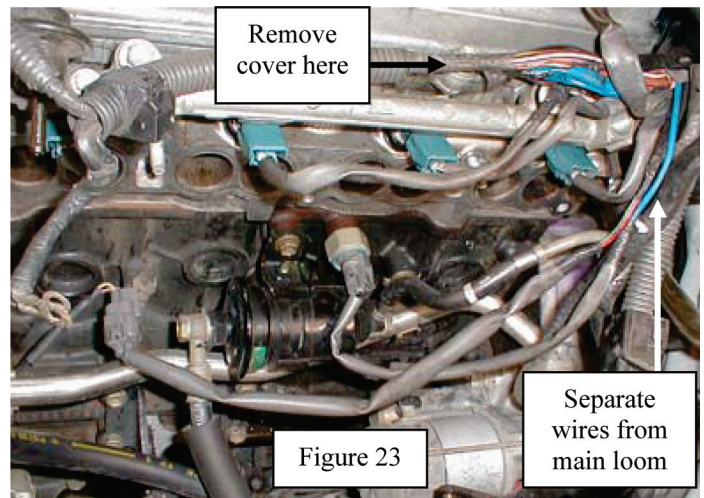

44. Connect the detonation sensor and crankshaft position sensor connectors before installing the supercharger.

Installation of the Supercharger

45. When installing the supercharger, the supercharger drive pulley and snout slides under the power steering pump return hose. See Figure 24.

Before sliding the supercharger manifold over the attachment studs, insert the fuel line banjo fitting through the manifold between intake ports three and four. It is easiest to do this as the manifold is being lowered into place after the supercharger snout is in position. Use another person if necessary to help with the fuel inlet banjo fitting. Snug all the nuts and bolts to secure the supercharger to the cylinder head. Start in the center of the manifold and work outward towards the ends. Torque fasteners to 22 ft-lbs.

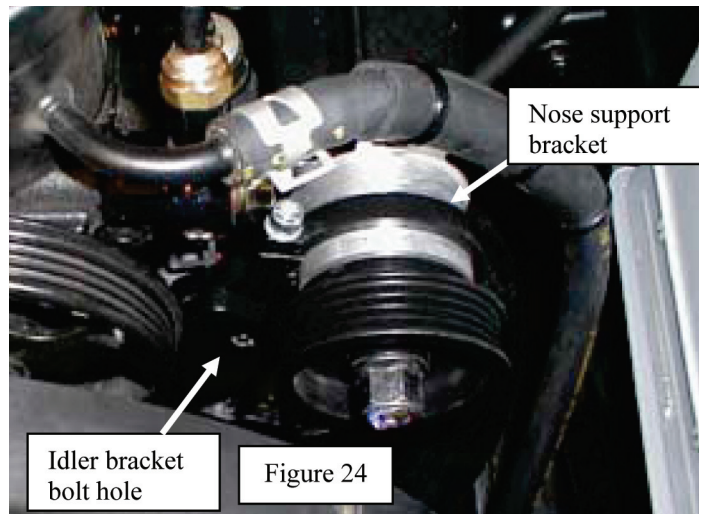

46. Rotate the supercharger nose support bracket to align the slot in the bracket with the idler bracket bolt hole. See Figure 24. Use the supplied 10mm x 1.25 x 25mm long hex bolt and 10mm washer to secure the nose support bracket to the idler bracket. Finger tighten bolt.

47. Using the 8mm flange head nut supplied, secure the upper portion of the manifold support to the 8mm stud that is in the bottom-side of the intake manifold. The stud should protrude through the slot in the manifold support bracket. See Figure 25. Tighten bracket to supercharger first, and then also tighten to the engine mount. Torque: 15 ft-lbs. Finally, torque the manifold bracket 8mm through bolt and nylock nut to 15 ft-lbs.

48. Tighten the 10mm bolt that secures the nose support bracket to the idler pulley bracket. Torque: 30 ft-lbs.

49. Tighten the socket head cap screw to secure the nose support bracket to the supercharger nose. Torque: 10 ft-lbs.

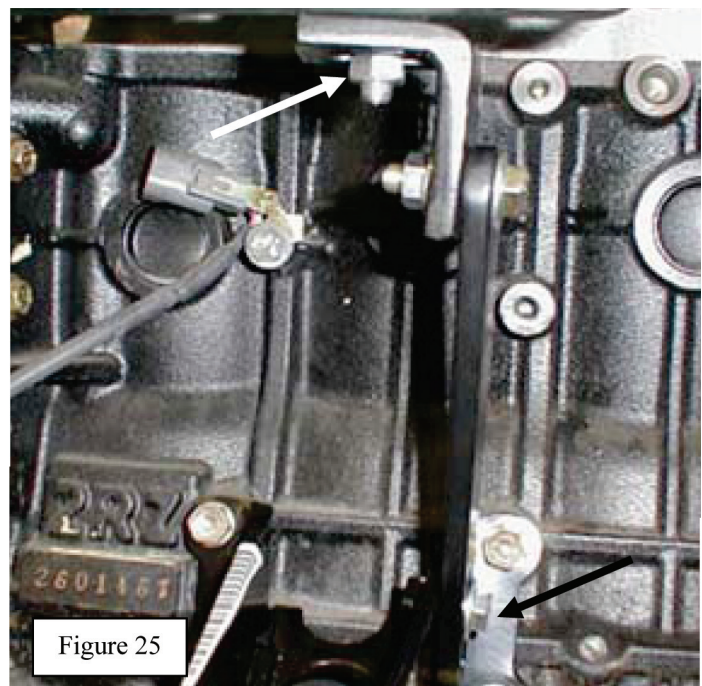

- 50. Check both the power steering pressure hose and return hose for clearance to the supercharger snout. Both lines should not touch the supercharger. Adjust lines as necessary.
- 51. Reconnect the fuel inlet banjo fitting to fuel rail. Torque: 22 ft-lbs.
- 52. Reconnect all four fuel injection connectors.
- 53. Attach injector wiring ground strap removed in Step 23 to the supercharger intake manifold using the supplied 6mm hex bolt and washer. Clean wires and the connection location before installing. See Figure 26. Torque: 6 ft-lbs

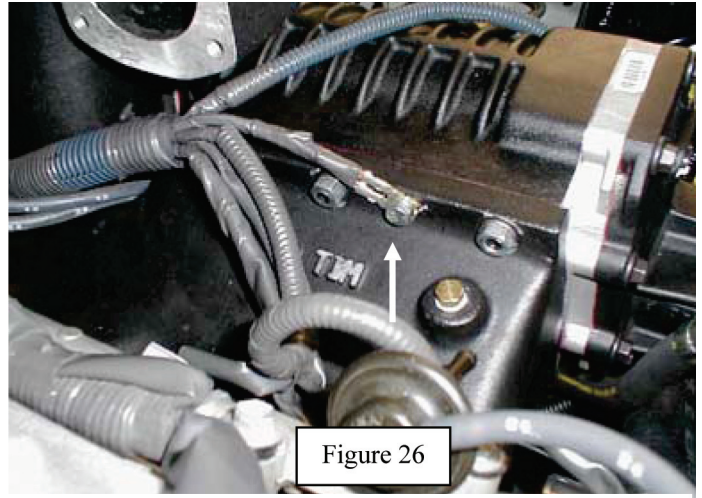

Figure 26

Note: If your vehicle has eight round intake manifold ports, then skip to step 64.
 If your vehicle has four oval ports, then follow steps 62 and 63.

- 54. Route the crankshaft position sensor connector down through the opening between intake port one and intake port two of the supercharger manifold and connect to the crankshaft position sensor.
- 55. Route detonation sensor connector through the intake manifold between ports two and three, and then connect to the detonation sensor.
- 56. Reconnect power steering idle up connector. Install the OE wiring bracket on to the supercharger stud. Torque nylock nut to 15 ft-lbs. See Figure 27 .
- 57. On vehicles with EGR, remove the EGR temperature sensor (Arrow A) and EGR modulator bracket (Arrow B) from the OE intake chamber. See Figure 28.

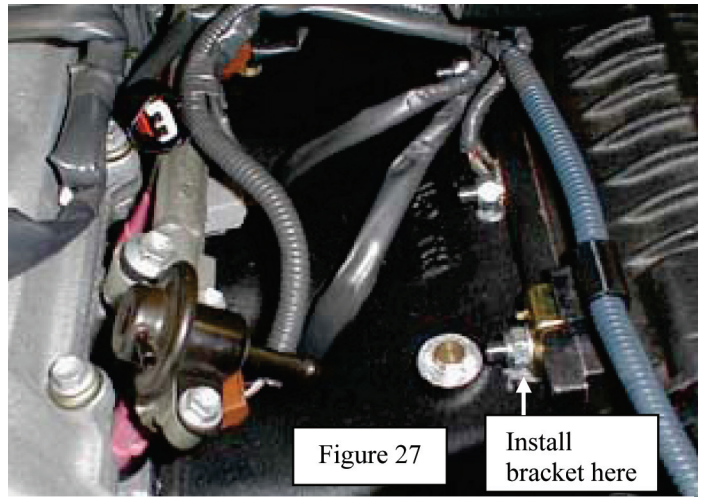

Figure 27

Install bracket here

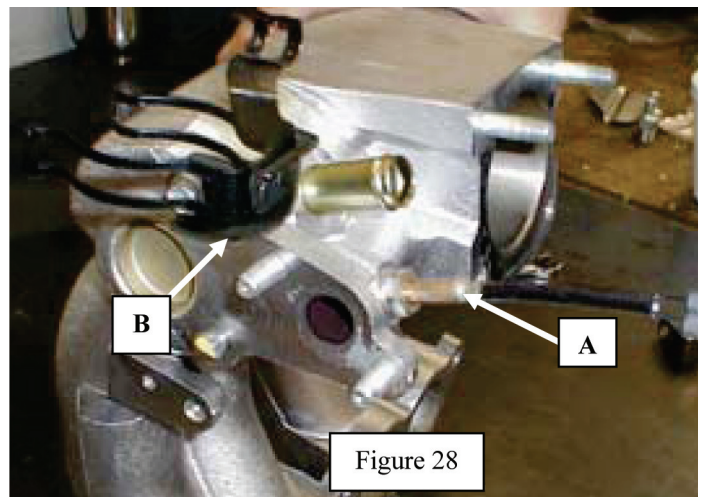
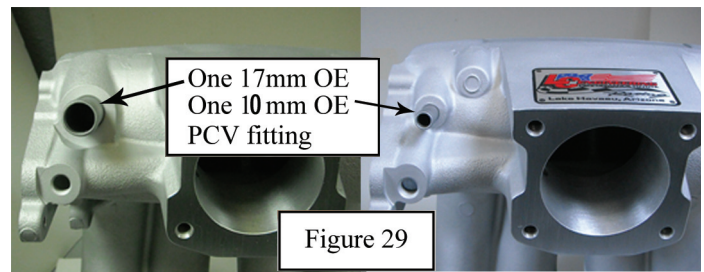

Figure 28

58. Check the OE intake chamber that was removed from the vehicle. Look at the quantity and location of the PCV /breather fitting/s that are next to the throttle body surface. See Figure 29.



59. Check the intake chamber to make sure that the quantity and location of the PCV/breather fitting/s match the OE intake chamber. See Figure 30.

Note: The intake chamber is photographed off the engine for clarity. If the fittings match, then proceed with Step 68. If the fittings do not match, then use the supplied fittings to duplicate the previous /breather fittings in the OE intake chamber. Re-use the 16mm nylon washers to seal the fittings into the intake chamber.

60. If vehicle has EGR, install the EGR temperature sensor (Arrow A) to the intake chamber. See Figure 30. Otherwise, install the supplied 10mm x 1.25 x 12mm long bolt. Teflon thread tape is recommended.

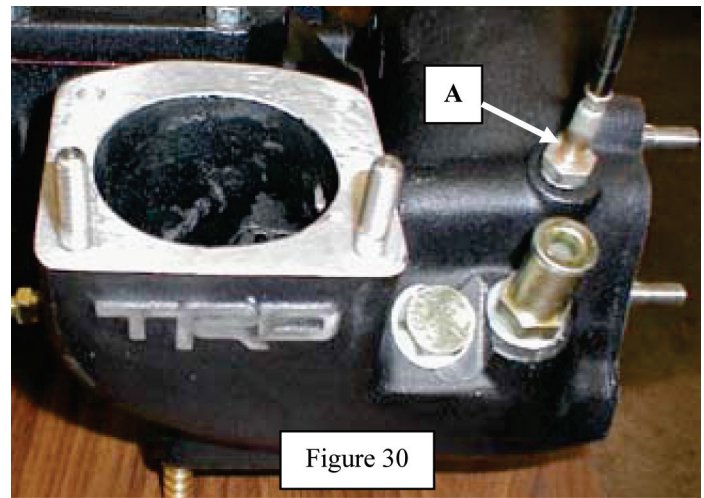

61. If vehicle has EGR then proceed with Steps 62 through 75, If vehicle has no EGR, then skip to Step 68

62. Use one of the supplied EGR gaskets and install the EGR valve to the backside of the intake chamber. See Figure 31. Use the OE EGR valve nuts removed in Step 14. Leave the nuts loose at this time.

63. Use the second supplied EGR gasket and connect the EGR feed tube to the EGR valve. Again, use the OE nuts removed in Step 13. Leave nuts loose at this time.

64. Torque EGR valve nuts: 14 ft-lbs.

65. Install EGR feed tube. Torque to 14 ft-lbs

66. Reconnect EGR coolant hose removed in Step 31.

67. Re-install the EGR modulator bracket to the backside of the intake manifold using the OE bolt removed in Step 65. Refer to Figure 31

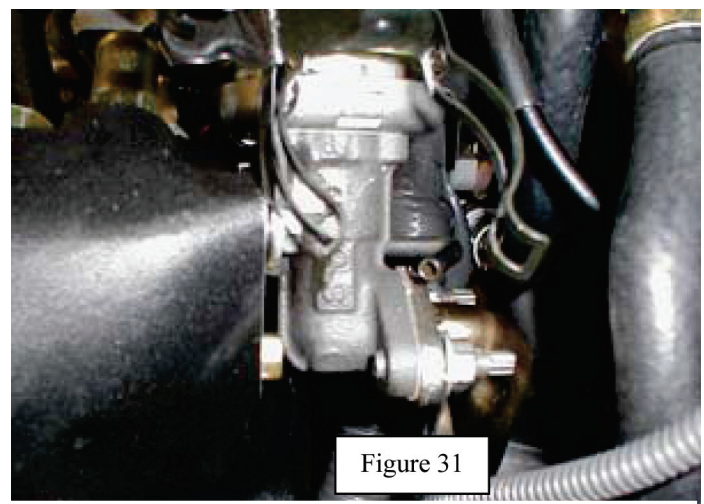

68. If the vehicle has no EGR, then use one EGR gasket, block-off plate, and two 8 x 1.25mm flange nuts to seal the EGR passage located on the backside of the intake chamber. See Figure 32. Torque nuts: 14 ft-lbs
69. Position supplied throttle body gasket on to the studs on the intake chamber. Position the OE throttle body also on the studs.
70. Reconnect TPS and IAC connectors to the sensors in the throttle body also reinstall coolant lines.
71. Reconnect cam position sensor connector removed in Step 27.
72. Tighten the OE nuts and bolts to secure the throttle body to the intake chamber. Torque: 14 ft-lbs
74. Reconnect the brake booster vacuum hose to the hose fitting on the side of the intake chamber. Cut hose if needed. See Figure 33 Arrow "A"
75. Remove the OE fuel return pipe and hose. Disconnect the OE hose at the hard line that is mounted on the inner fender panel. Install the new supplied fuel return hose using the OE clamps removed in Step 24. Route the new hose under the supercharger. Hook up new line at the frame rail.
76. Install the supplied fuel block under the stock fuel pressure regulator. Route the 5th injector fuel line towards the fire wall use supplied Adel clamps to mount.
77. Install supercharger drive belt using the supplied drive belt routing label as a guide. Find a suitable area under the hood to mount the drive belt routing label. Clean area to remove any dirt or grease and affix label.
78. Re-install the radiator fan shroud removed in Step 38.
79. Re-install the steel line that was removed from the fan shroud in Step 35.

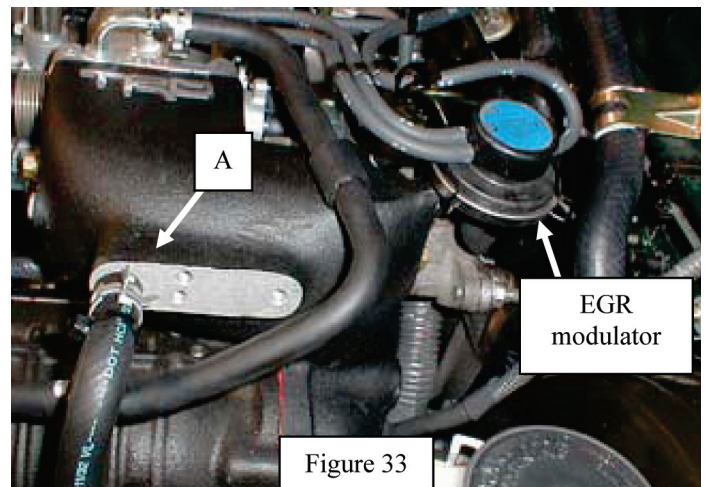
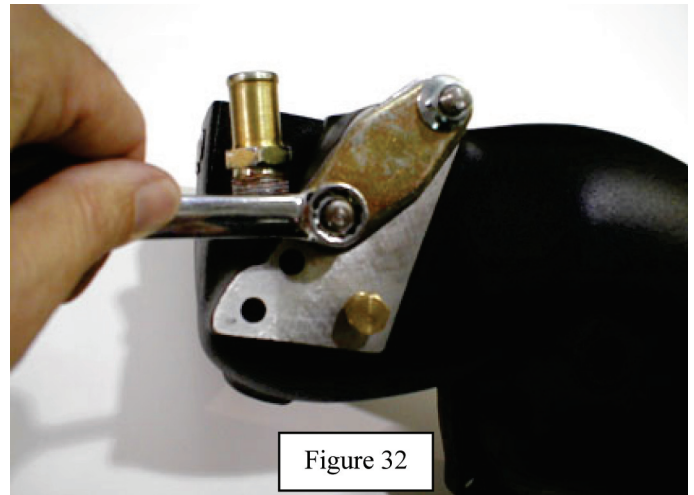

80. Remove the valve cover bolt and sealing washer from the rear hole on the driver side of the valve cover. See Figure 34. Remove the sealing washer from the bolt. Use the valve cover bolt to mount the supplied "Z" bracket onto the valve cover. The bracket should sit on top of the sealing washer. Tighten cam cover bolt.

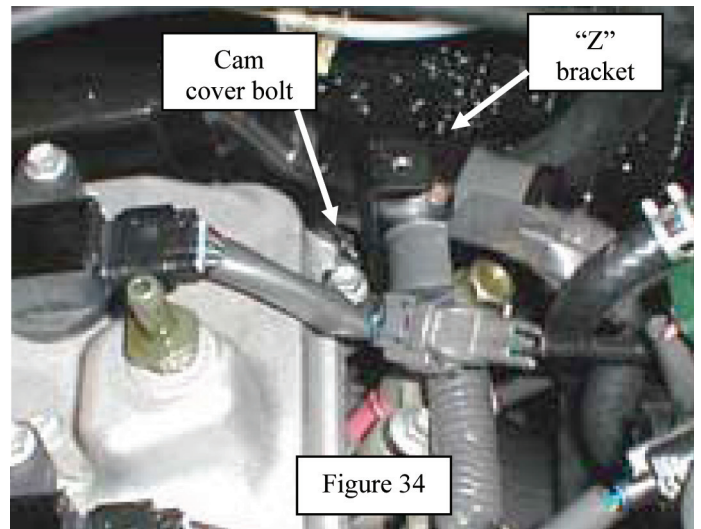

81. Mount the EGR modulator VSV to the "Z" bracket. See Figure 35. Use the OE 6mm bolt and washer removed in Step 26. Torque bolt: 6 ft-lbs.
82. Reconnect the VSV hoses and EGR modulator hoses per the vacuum diagram on the under side of the vehicle hood.

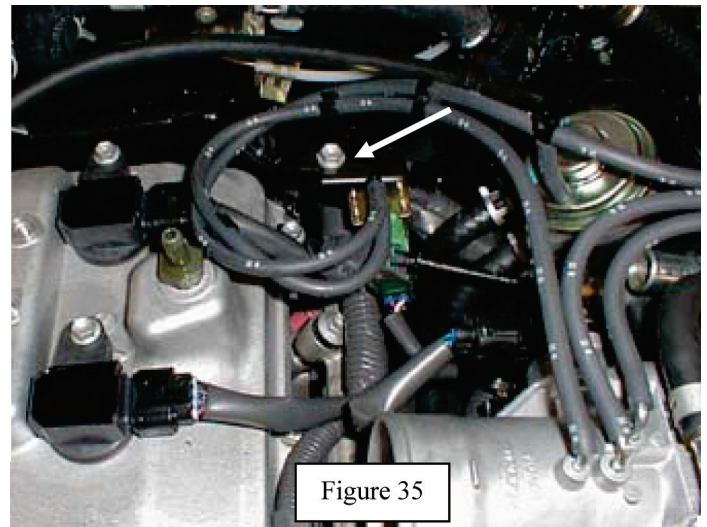

83. Reconnect the PCV hose from the PCV valve to the PCV fitting on the intake manifold. See Figure 36 Arrow "A"
84. Reconnect the valve cover breather hose to the fitting on the throttle body. See Figure 36, Arrow "B".

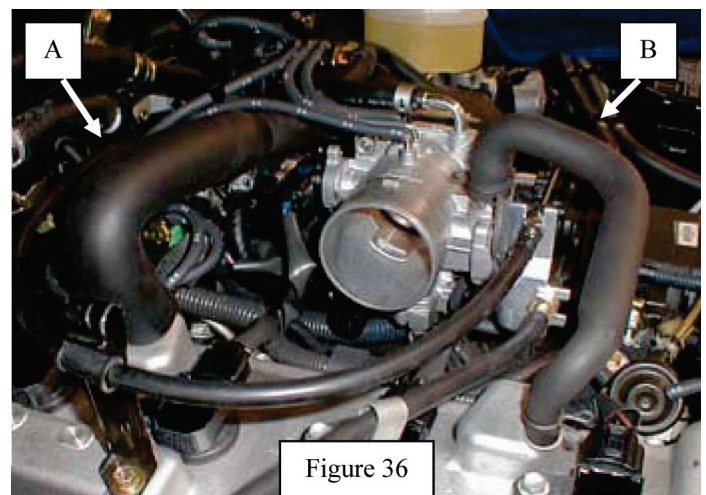

85. Re-install intake air connector onto throttle body. See Figure 37. Secure intake air connector-to-connector bracket using two OE nuts removed in Step 2. Torque nuts: 13 ft-lbs.

86. Re-install air cleaner hose with resonator.

87. On 1995-2001 vehicles, follow Steps 95 and 96. Mount OE DLC 1 bracket to the unused boss on the cylinder head. See Figure 38. Use the OE bolt removed in Step 18. Torque bolt: 6 ft-lbs.

88. Slide the DLC onto the bracket until it locks into place .

89. Install the supplied 1/8" NPT barb fitting into the manifold using thread sealant on the threads. Connect to the power steering vacuum line. On kits with the fifth injector install the tee fitting and run vacuum line though the firewall so it may connect to the split second box

90. Reconnect the fuel regulator hose

91. Re check all vacuum lines for proper placement and connection

92. The use of this kit requires the use of Premium high octane fuel only Min. 92.

93. In States that require smog checks apply the EO decal to the underside of the hood This will alert smog inspectors that the kit is 50 state legal

94. On vehicles that do not need the 1/4" vacuum hose fitting that is installed on the front of the throttle body manifold use a rubber cap to block it off. see Figure 40.

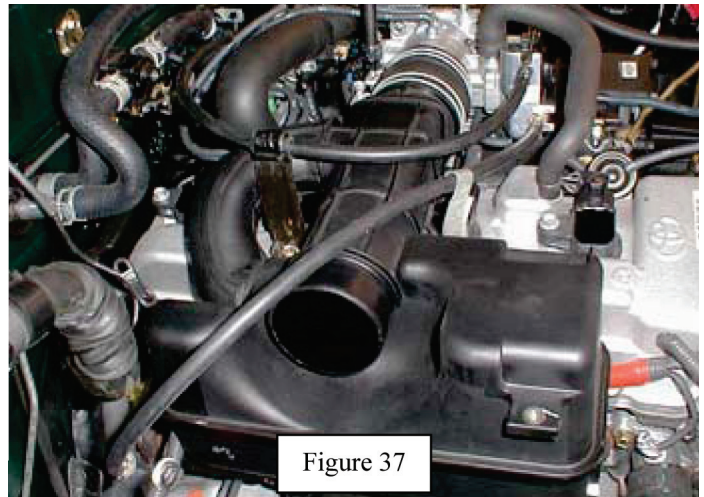

Figure 37

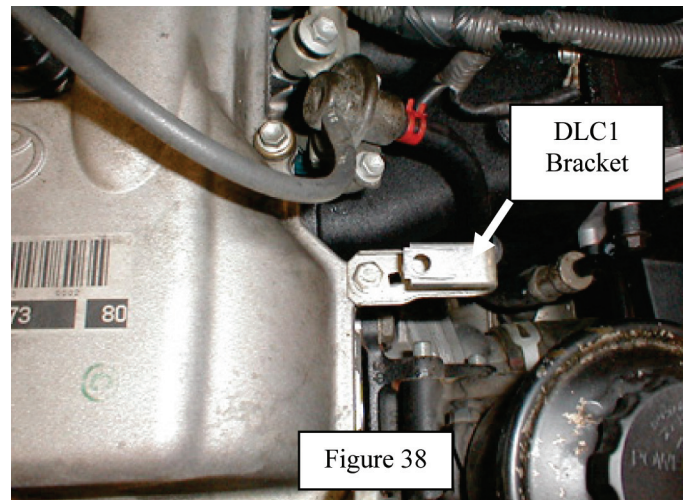

Figure 38

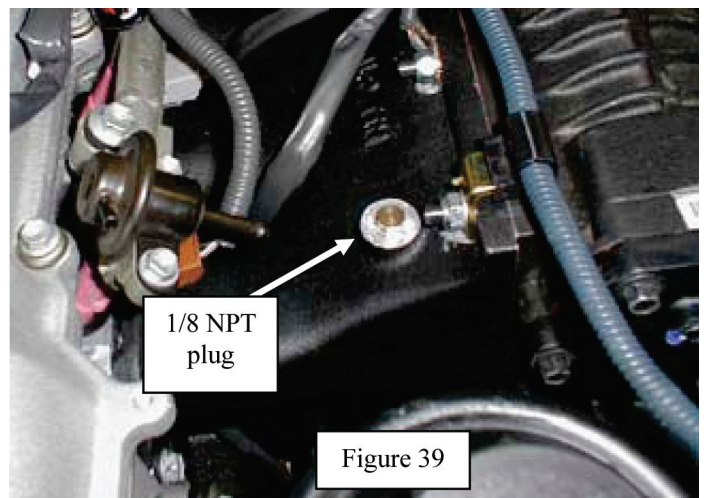
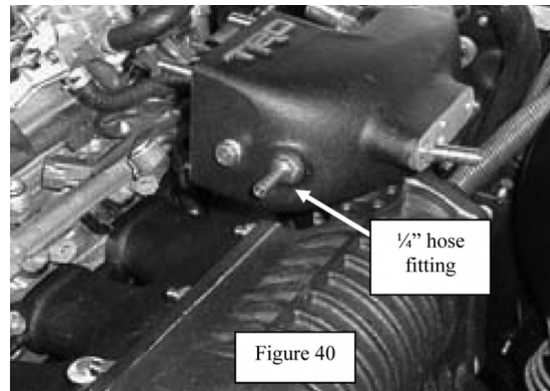

Figure 39

95. Use cable ties to secure all wiring and vacuum line as necessary.
96. Re-install battery cable.
97. Start Engine and check for vacuum and air leaks. Diagnose and repair any problems found.



On vehicles that are running low boost kits, the computer will make adjustment for the increase in air to the engine. Please know that the vehicles will not run proper until the computer makes the necessary adjustments. It will take around two tanks of gas or several hundred miles (approx).

Our High Boost Kits will Require the install of the FTC Split Second piggy back fuel and timing controller. See instructions below of this for the High Boost Controller install instructions.



NOTE: In order to reach optimum performance the vehicle must be driven several hundred miles. Usually two tanks of fuel. This will allow the ECU to fully adjust to the additional air flow. Premium fuel is required to be used .

Location of ECM on Tacomas

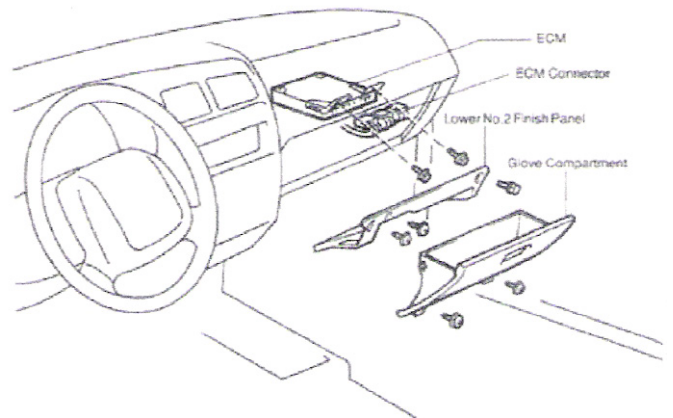

Installation of the FTC Split Second controller:

1. The Battery must be disconnected during the instal of the FTC.
2. The Tacoma ECU is installed behind the glove box. Remove glove box door and lower finish panel to gain access to the ECU wiring harness.
3. All conections to the ECU should be of solder and shrink wrap for the best possible conec tion. Keep all conections at least 2” away from the ECU. Cut wires at least 2” away from ECU.
4. Hook up vaccum line that was brought in from step 89 (on the supercharger install instructions).
5. Follow the ECU wire Diagram for your plug configuration. If you do not see the proper ECU plug pin out, call LCE's Tech Support 928-855-6341. Please make sure you have your VIN in hand.

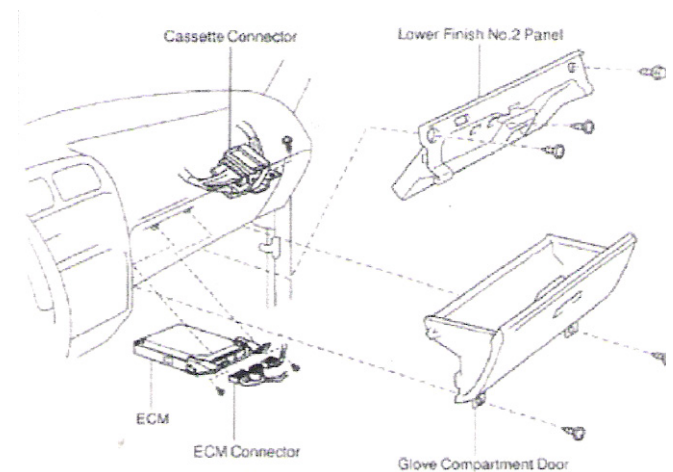

Use and Installation Instructions For the FTC Controller

- 1) Tuning can be done using the R4 software included on cd but not required.
- 2) Disconnect the battery before making connections to the factory wiring harness.
- 3) The following wire will need to be hooked up to the stock ECU see diagrams in the following pages.
- 4) Use solder and heat shrink for the best possible electrical connections DO NOT USE quick connectors.
- 5) **The following instructions are for loading programs to the controller. These units come already programmed by LCE for 4 Cylinder Tacomas. Instructions provided just in case the controller needs to be re-programmed in the future.**
 - 1) Use with R4 software.
 - 2) Select Vac/Pressure and Additional Injector Controller under system settings. Refer to the AIC1 and FTC1 data sheets for more information.
 - 3) Select 2-cylinder, 2-stroke under Engine Settings.
 - 4) Program timing retard in Map table A.
 - 5) The cell values can range from 0 to 20. A value of 20 will result in 20 degrees of retard. (Cell values can have one decimal place. For example 10.1. There are a total of 200 levels available for cell value).
 - 6) Program the fuel in Map table B.
 - 7) The cell value represents the additional injector on-time in milliseconds. The minimum practical cell value is 1.0 the maximum cell value will have a corresponding duty cycle of 40%.
 - 8) The highest cell value is 25.5, but you should never get anywhere near that number. (Cell values can have one decimal place. For example 10.1. There are a total of 200 levels available for cell value).
 - 9) Program the enrichment threshold and optional relay activation through the output B mode selection. Typical settings are for Over Pressure and a threshold of 1 psi.
- 6) Make sure the vacuum line is connected to the FTC controller from the intake manifold.
- 7) Reconnect the battery

Note Advanced Option Not Required:

Orange wire is not used in this set up If you would like to control an external load with the R4 software connect the ORANGE wire as follows.. Connect the ORANGE relay driver wire to the negative side of the relay coil Connect the coil positive to a fused B+ circuit Switch the load through the relay contacts, Set up the turn-on threshold for the relay under options, output settings and output B The threshold can be set according to any combination of RPM and pressure set points

If Using the advanced tuning options you will need a windows computer and serial cable for connections to the FTC controller. The R4 software will need to be installed if you want to use the advanced options and tune the FTC see the included R4 instructions and CD Rom.

Vacuum Diagrams

2.4 Vacuum Diagram
Production Dates:
01/95-08/98

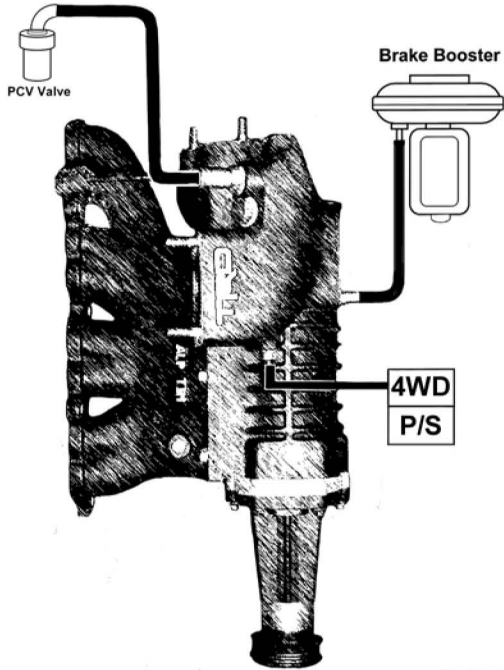

2.4 Vacuum Diagram
Production Dates:
09/98 to Present

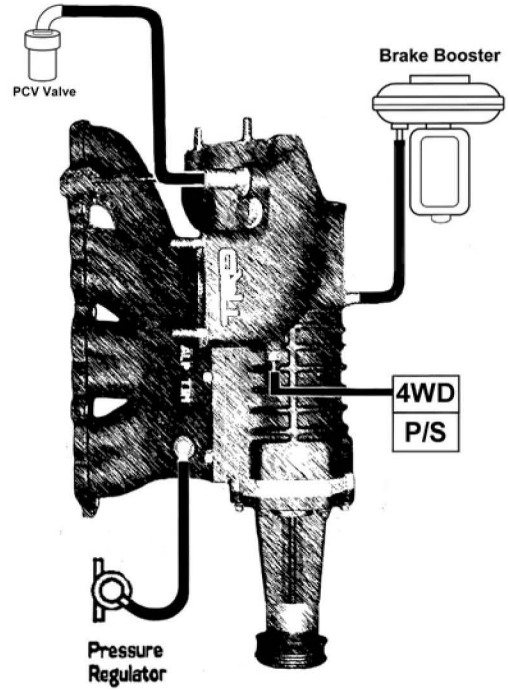

2.7 Vacuum Diagram
Production Dates:
01/95 to Present

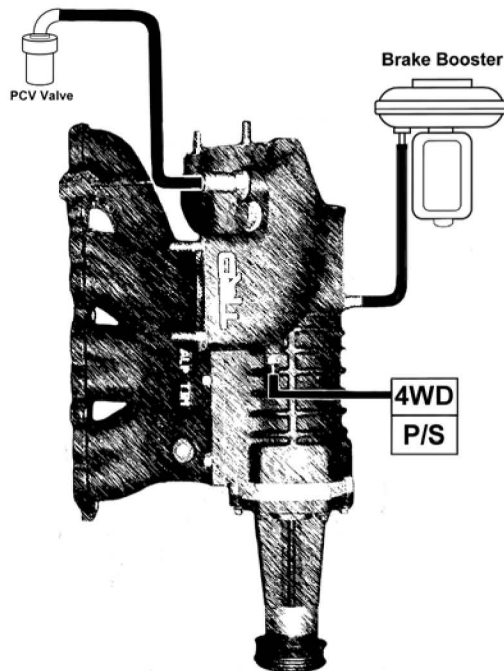

FTC1-115D Fuel/Timing Calibrator for 2.4L Toyota 2RZ

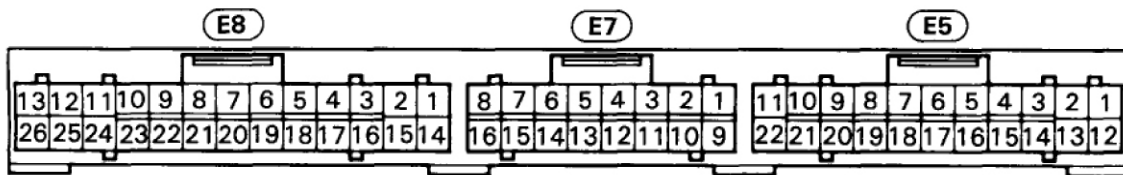

Use and Installation Instructions (ECU referenced to 1995.5 thru 1997 2RZ-FE Tacoma):

- 1) Disconnect the battery before making connections to the factory wiring harness.
- 2) Use solder and heat shrink for the best possible electrical connections.
- 3) The following wires are in the main wire group.
- 4) Connect the **RED** wire (B+) to the WHITE/RED wire on ECU pin E5-12.
- 5) Connect the **BLACK** wire (B-) to the BROWN wire on ECU pin E8-14.
- 6) Connect the **BLACK/YELLOW** wire (tach) to the BLACK/YELLOW wire on ECU pin E8-3.
- 7) Cut the RED (crank sensor) wire leading to ECU pin E8-4.
- 8) Connect the **GREEN** wire to the cut wire leading to the crank sensor.
- 9) Connect the **GREEN/RED** wire to the cut wire leading to the ECU crank sensor input.
- 10) Cut the YELLOW (cam sensor) wire leading to ECU pin E8-5.
- 11) Connect the **BLUE** wire to the cut wire leading to the cam sensor.
- 12) Connect the **BLUE/WHITE** wire to the cut wire leading to the ECU cam sensor input.
- 13) Cut the WHITE (OX1) wire leading to ECU pin E7-6.
- 14) Connect the **PINK** wire to the cut wire leading to the sensor.
- 15) Connect the **PINK/BLUE** wire to the cut wire leading to the OX1 ECU input.
- 16) Cut the BLACK (OX2) wire leading to ECU pin E7-5.
- 17) Connect the **WHITE** wire to the cut wire leading to the sensor.
- 18) Connect the **WHITE/GREEN** wire to the cut wire leading to the OX1 ECU input.
- 19) Connect the **RED** and **TAN** wires in the small wire group to the corresponding wires on the injector harness.
- 20) If you would like to control an external load with the R4 software connect the **ORANGE** wire as follows.
- 21) Connect the **ORANGE** relay driver wire to the negative side of the relay coil.
- 22) Connect the coil positive to a fused B+ circuit.
- 23) Switch the load through the relay contacts.
- 24) Set up the turn-on threshold for the relay under options, output settings and output B.
- 25) The threshold can be set according to any combination of RPM and pressure set points.
- 26) Connect the vacuum line to intake manifold vacuum.
- 27) Reconnect the battery.

FTC1-115D Fuel/Timing Calibrator for 2.7L Toyota 3RZ

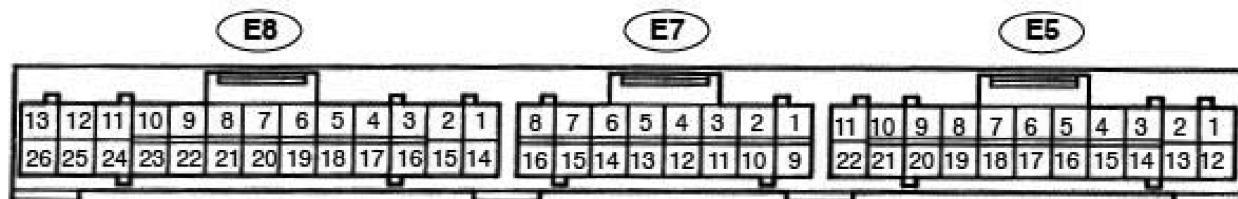

Use and Installation Inst (ECU referenced to 1995.5 and 1996 3RZ-FE Tacoma with MT):

- 1) Disconnect the battery before making connections to the factory wiring harness.
- 2) Use solder and heat shrink for the best possible electrical connections.
- 3) The following wires are in the main wire group.
- 4) Connect the **RED** wire (B+) to the WHITE/RED wire on ECU pin E5-12.
- 5) Connect the **BLACK** wire (B-) to the BROWN wire on ECU pin E8-13.
- 6) Connect the **BLACK/YELLOW** wire (tach) to the BLACK/YELLOW wire on ECU pin E8-3.
- 7) Cut the RED (crank sensor) wire leading to ECU pin E8-4.
- 8) Connect the **GREEN** wire to the cut wire leading to the crank sensor.
- 9) Connect the **GREEN/RED** wire to the cut wire leading to the ECU crank sensor input.
- 10) Cut the YELLOW (cam sensor) wire leading to ECU pin E8-5.
- 11) Connect the **BLUE** wire to the cut wire leading to the cam sensor.
- 12) Connect the **BLUE/WHITE** wire to the cut wire leading to the ECU cam sensor input.
- 13) Cut the WHITE (OX1) wire leading to ECU pin E7-6.
- 14) Connect the **PINK** wire to the cut wire leading to the sensor.
- 15) Connect the **PINK/BLUE** wire to the cut wire leading to the OX1 ECU input.
- 16) Cut the BLACK (OX2) wire leading to ECU pin E7-5.
- 17) Connect the **WHITE** wire to the cut wire leading to the sensor.
- 18) Connect the **WHITE/GREEN** wire to the cut wire leading to the OX1 ECU input.
- 19) Connect the **RED** and **TAN** wires in the small wire group to the corresponding wires on the injector harness.
- 20) If you would like to control an external load with the R4 software connect the **ORANGE** wire as follows.
- 21) Connect the **ORANGE** relay driver wire to the negative side of the relay coil.
- 22) Connect the coil positive to a fused B+ circuit.
- 23) Switch the load through the relay contacts.
- 24) Set up the turn-on threshold for the relay under options, output settings and output B.
- 25) The threshold can be set according to any combination of RPM and pressure set points.
- 26) Connect the vacuum line to intake manifold vacuum.
- 27) Reconnect the battery.

FTC1-115D Fuel/Timing Calibrator for 2.7L Toyota 3RZ

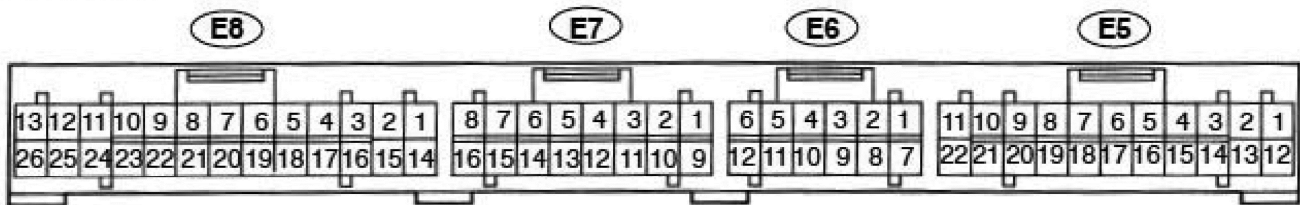

Use and Installation Inst (ECU referenced to 1995.5 and 1996 3RZ-FE Tacoma with AT):

- 1) Disconnect the battery before making connections to the factory wiring harness.
- 2) Use solder and heat shrink for the best possible electrical connections.
- 3) The following wires are in the main wire group.
- 4) Connect the **RED** wire (B+) to the WHITE/RED wire on ECU pin E5-12.
- 5) Connect the **BLACK** wire (B-) to the BROWN wire on ECU pin E8-13.
- 6) Connect the **BLACK/YELLOW** wire (tach) to the BLACK/YELLOW wire on ECU pin E8-17.
- 7) Cut the RED (crank sensor) wire leading to ECU pin E6-12.
- 8) Connect the **GREEN** wire to the cut wire leading to the crank sensor.
- 9) Connect the **GREEN/RED** wire to the cut wire leading to the ECU crank sensor input.
- 10) Cut the YELLOW (cam sensor) wire leading to ECU pin E6-11.
- 11) Connect the **BLUE** wire to the cut wire leading to the cam sensor.
- 12) Connect the **BLUE/WHITE** wire to the cut wire leading to the ECU cam sensor input.
- 13) Cut the WHITE (OX1) wire leading to ECU pin E7-5.
- 14) Connect the **PINK** wire to the cut wire leading to the sensor.
- 15) Connect the **PINK/BLUE** wire to the cut wire leading to the OX1 ECU input.
- 16) Cut the BLACK (OX2) wire leading to ECU pin E7-13.
- 17) Connect the **WHITE** wire to the cut wire leading to the sensor.
- 18) Connect the **WHITE/GREEN** wire to the cut wire leading to the OX2 ECU input.
- 19) Connect the **RED** and **TAN** wires in the small wire group to the corresponding wires on the injector harness.
- 20) If you would like to control an external load with the R4 software connect the **ORANGE** wire as follows.
- 21) Connect the **ORANGE** relay driver wire to the negative side of the relay coil.
- 22) Connect the coil positive to a fused B+ circuit.
- 23) Switch the load through the relay contacts.
- 24) Set up the turn-on threshold for the relay under options, output settings and output B.
- 25) The threshold can be set according to any combination of RPM and pressure set points.
- 26) Connect the vacuum line to intake manifold vacuum.
- 27) Reconnect the battery.

FTC1-115D Fuel/Timing Calibrator for 2.4L Toyota 2RZ

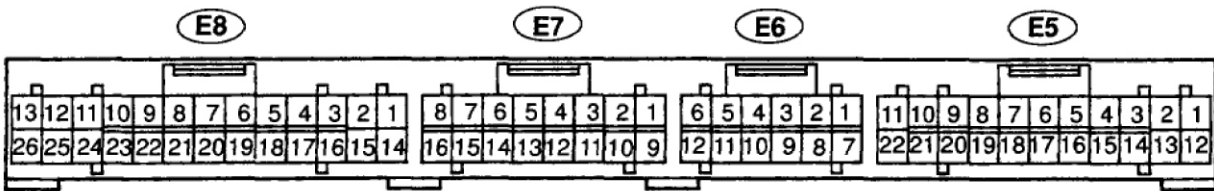

Use and Installation Instructions (ECU referenced to 1998 and 1999 2RZ-FE Tacoma):

- 1) Disconnect the battery before making connections to the factory wiring harness.
- 2) Use solder and heat shrink for the best possible electrical connections.
- 3) The following wires are in the main wire group.
- 4) Connect the **RED** wire (B+) to the WHITE/RED wire on ECU pin E5-12.
- 5) Connect the **BLACK** wire (B-) to the BROWN wire on ECU pin E8-24.
- 6) Connect the **BLACK/YELLOW** wire (tach) to the BLACK/YELLOW wire on ECU pin E8-17.
- 7) Cut the RED (crank sensor) wire leading to ECU pin E6-12.
- 8) Connect the **GREEN** wire to the cut wire leading to the crank sensor.
- 9) Connect the **GREEN/RED** wire to the cut wire leading to the ECU crank sensor input.
- 10) Cut the YELLOW (cam sensor) wire leading to ECU pin E6-11.
- 11) Connect the **BLUE** wire to the cut wire leading to the cam sensor.
- 12) Connect the **BLUE/WHITE** wire to the cut wire leading to the ECU cam sensor input.
- 13) Cut the WHITE (OX1) wire leading to ECU pin E7-5.
- 14) Connect the **PINK** wire to the cut wire leading to the sensor.
- 15) Connect the **PINK/BLUE** wire to the cut wire leading to the OX1 ECU input.
- 16) Cut the BLACK (OX2) wire leading to ECU pin E7-13.
- 17) Connect the **WHITE** wire to the cut wire leading to the sensor.
- 18) Connect the **WHITE/GREEN** wire to the cut wire leading to the OX2 ECU input.
- 19) Connect the **RED** and **TAN** wires in the small wire group to the corresponding wires on the injector harness.
- 20) If you would like to control an external load with the R4 software connect the **ORANGE** wire as follows.
- 21) Connect the **ORANGE** relay driver wire to the negative side of the relay coil.
- 22) Connect the coil positive to a fused B+ circuit.
- 23) Switch the load through the relay contacts.
- 24) Set up the turn-on threshold for the relay under options, output settings and output B.
- 25) The threshold can be set according to any combination of RPM and pressure set points.
- 26) Connect the vacuum line to intake manifold vacuum.
- 27) Reconnect the battery.

FTC1-115D Fuel/Timing Calibrator for 2.7L Toyota 3RZ

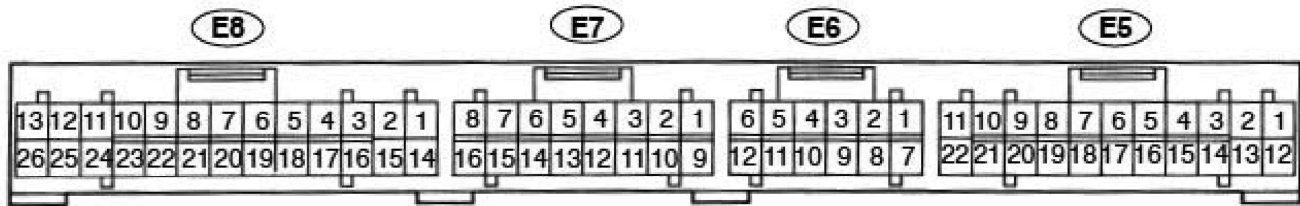

Use and Installation Inst (ECU referenced to 1997 thru 1999 3RZ-FE Tacoma):

- 1) Disconnect the battery before making connections to the factory wiring harness.
- 2) Use solder and heat shrink for the best possible electrical connections.
- 3) The following wires are in the main wire group.
- 4) Connect the **RED** wire (B+) to the WHITE/RED wire on ECU pin E5-12.
- 5) Connect the **BLACK** wire (B-) to the BROWN wire on ECU pin E8-13.
- 6) Connect the **BLACK/YELLOW** wire (tach) to the BLACK/YELLOW wire on ECU pin E8-17.
- 7) Cut the RED (crank sensor) wire leading to ECU pin E6-12.
- 8) Connect the **GREEN** wire to the cut wire leading to the crank sensor.
- 9) Connect the **GREEN/RED** wire to the cut wire leading to the ECU crank sensor input.
- 10) Cut the YELLOW (cam sensor) wire leading to ECU pin E6-11.
- 11) Connect the **BLUE** wire to the cut wire leading to the cam sensor.
- 12) Connect the **BLUE/WHITE** wire to the cut wire leading to the ECU cam sensor input.
- 13) Cut the WHITE (OX1) wire leading to ECU pin E7-5.
- 14) Connect the **PINK** wire to the cut wire leading to the sensor.
- 15) Connect the **PINK/BLUE** wire to the cut wire leading to the OX1 ECU input.
- 16) Cut the BLACK (OX2) wire leading to ECU pin E7-13.
- 17) Connect the **WHITE** wire to the cut wire leading to the sensor.
- 18) Connect the **WHITE/GREEN** wire to the cut wire leading to the OX2 ECU input.
- 19) Connect the **RED** and **TAN** wires in the small wire group to the corresponding wires on the injector harness.
- 20) If you would like to control an external load with the R4 software connect the **ORANGE** wire as follows.
- 21) Connect the **ORANGE** relay driver wire to the negative side of the relay coil.
- 22) Connect the coil positive to a fused B+ circuit.
- 23) Switch the load through the relay contacts.
- 24) Set up the turn-on threshold for the relay under options, output settings and output B.
- 25) The threshold can be set according to any combination of RPM and pressure set points.
- 26) Connect the vacuum line to intake manifold vacuum.
- 27) Reconnect the battery.

FTC1-115D Fuel/Timing Calibrator for 2.4L Toyota 2RZ

ECM Terminals

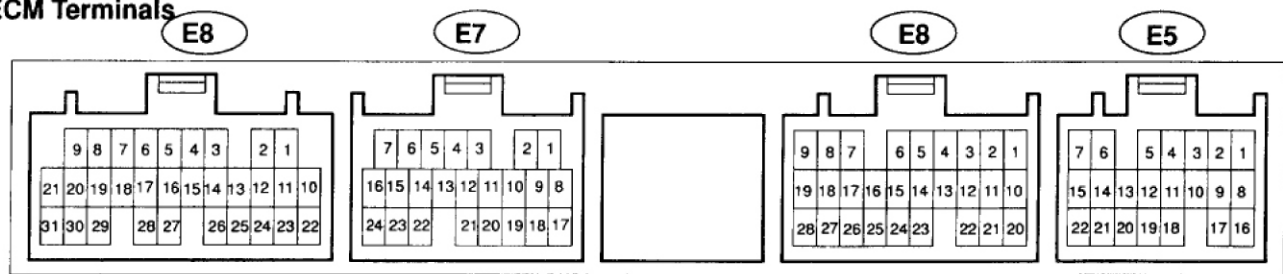

Use and Installation Instructions (ECU referenced to 2000 California 2RZ-FE Tacoma):

- 1) Disconnect the battery before making connections to the factory wiring harness.
- 2) Use solder and heat shrink for the best possible electrical connections.
- 3) The following wires are in the main wire group.
- 4) Connect the **RED** wire (B+) to the WHITE/RED wire on ECU pin E5-16.
- 5) Connect the **BLACK** wire (B-) to the BROWN wire on ECU pin E7-17.
- 6) Connect the **BLACK/YELLOW** wire (tach) to the BLACK/YELLOW wire on ECU pin E8-10.
- 7) Cut the RED (crank sensor) wire leading to ECU pin E7-16.
- 8) Connect the **GREEN** wire to the cut wire leading to the crank sensor.
- 9) Connect the **GREEN/RED** wire to the cut wire leading to the ECU crank sensor input.
- 10) Cut the YELLOW (cam sensor) wire leading to ECU pin E7-15.
- 11) Connect the **BLUE** wire to the cut wire leading to the cam sensor.
- 12) Connect the **BLUE/WHITE** wire to the cut wire leading to the ECU cam sensor input.
- 13) Connect the **PINK/BLUE** wire to the WHITE wire on ECU pin E7-11.
- 14) The **PINK** wire is not used and can be left disconnected.
- 15) Cut the BLACK (OXS) wire leading to ECU pin E7-10.
- 16) Connect the **WHITE** wire to the cut wire leading to the sensor.
- 17) Connect the **WHITE/GREEN** wire to the cut wire leading to the OXS ECU input.
- 18) Connect the **RED** and **TAN** wires in the small wire group to the corresponding wires on the injector harness.
- 19) If you would like to control an external load with the R4 software connect the **ORANGE** wire as follows.
- 20) Connect the **ORANGE** relay driver wire to the negative side of the relay coil.
- 21) Connect the coil positive to a fused B+ circuit.
- 22) Switch the load through the relay contacts.
- 23) Set up the turn-on threshold for the relay under options, output settings and output B.
- 24) The threshold can be set according to any combination of RPM and pressure set points.
- 25) Connect the vacuum line to intake manifold vacuum.
- 26) Reconnect the battery.

FTC1-115D Fuel/Timing Calibrator for 2.7L Toyota 3RZ

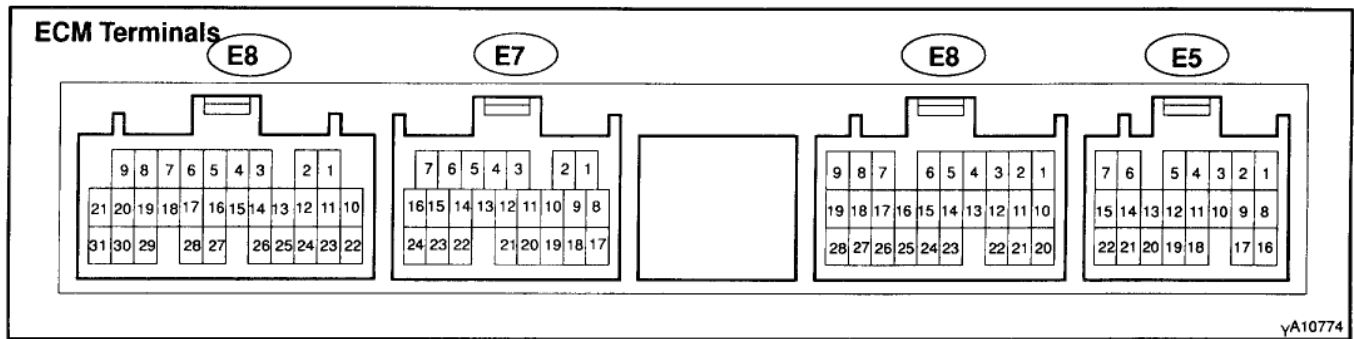

Use and Installation Instructions (ECU referenced to 2000 CA 3RZ-FE Tacoma):

- 1) Disconnect the battery before making connections to the factory wiring harness.
- 2) Use solder and heat shrink for the best possible electrical connections.
- 3) The following wires are in the main wire group.
- 4) Connect the **RED** wire (B+) to the **WHITE/RED** wire on ECU pin E5-16.
- 5) Connect the **BLACK** wire (B-) to the **BROWN** wire on ECU pin E7-17.
- 6) Connect the **BLACK/YELLOW** wire (tach) to the **BLACK/YELLOW** wire on ECU pin E8-10.
- 7) Cut the **RED** (crank sensor) wire leading to ECU pin E7-16.
- 8) Connect the **GREEN** wire to the cut wire leading to the crank sensor.
- 9) Connect the **GREEN/RED** wire to the cut wire leading to the ECU crank sensor input.
- 10) Cut the **YELLOW** (cam sensor) wire leading to ECU pin E7-15.
- 11) Connect the **BLUE** wire to the cut wire leading to the cam sensor.
- 12) Connect the **BLUE/WHITE** wire to the cut wire leading to the ECU cam sensor input.
- 13) Connect the **PINK/BLUE** wire to the **WHITE (AF+)** wire on ECU pin E7-11.
- 14) The **PINK** wire is not used and can be left disconnected.
- 15) Cut the **BLACK (OXS)** wire leading to ECU pin E7-10.
- 16) Connect the **WHITE** wire to the cut wire leading to the O2 sensor.
- 17) Connect the **WHITE/GREEN** wire to the cut wire leading to the ECU O2 sensor input.
- 18) Connect the **RED** and **TAN** wires in the small wire group to the corresponding wires on the injector harness.
- 19) If you would like to control an external load with the R4 software connect the **ORANGE** wire as follows.
- 20) Connect the **ORANGE** relay driver wire to the negative side of the relay coil.
- 21) Connect the coil positive to a fused B+ circuit.
- 22) Switch the load through the relay contacts.
- 23) Set up the turn-on threshold for the relay under options, output settings and output B.
- 24) The threshold can be set according to any combination of RPM and pressure set points.
- 25) Connect the vacuum line to intake manifold vacuum.
- 26) Reconnect the battery.

FTC1-115D Fuel/Timing Calibrator for 2.4L Toyota 2RZ

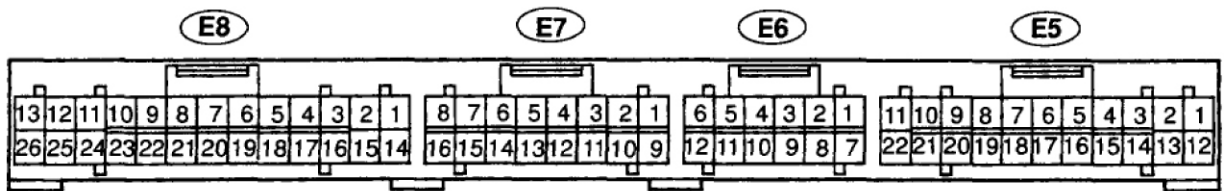

Use and Installation Instructions (ECU referenced to 2000 Non-CA 2RZ-FE Tacoma):

- 1) Disconnect the battery before making connections to the factory wiring harness.
- 2) Use solder and heat shrink for the best possible electrical connections.
- 3) The following wires are in the main wire group.
- 4) Connect the **RED** wire (B+) to the WHITE/RED wire on ECU pin E5-12.
- 5) Connect the **BLACK** wire (B-) to the BROWN wire on ECU pin E8-24.
- 6) Connect the **BLACK/YELLOW** wire (tach) to the BLACK/YELLOW wire on ECU pin E8-17.
- 7) Cut the RED (crank sensor) wire leading to ECU pin E6-12.
- 8) Connect the **GREEN** wire to the cut wire leading to the crank sensor.
- 9) Connect the **GREEN/RED** wire to the cut wire leading to the ECU crank sensor input.
- 10) Cut the YELLOW (cam sensor) wire leading to ECU pin E6-11.
- 11) Connect the **BLUE** wire to the cut wire leading to the cam sensor.
- 12) Connect the **BLUE/WHITE** wire to the cut wire leading to the ECU cam sensor input.
- 13) Cut the WHITE (OX1) wire leading to ECU pin E7-5.
- 14) Connect the **PINK** wire to the cut wire leading to the sensor.
- 15) Connect the **PINK/BLUE** wire to the cut wire leading to the OX1 ECU input.
- 16) Cut the BLACK (OX2) wire leading to ECU pin E7-13.
- 17) Connect the **WHITE** wire to the cut wire leading to the sensor.
- 18) Connect the **WHITE/GREEN** wire to the cut wire leading to the OX2 ECU input.
- 19) Connect the **RED** and **TAN** wires in the small wire group to the corresponding wires on the injector harness.
- 20) If you would like to control an external load with the R4 software connect the **ORANGE** wire as follows.
- 21) Connect the **ORANGE** relay driver wire to the negative side of the relay coil.
- 22) Connect the coil positive to a fused B+ circuit.
- 23) Switch the load through the relay contacts.
- 24) Set up the turn-on threshold for the relay under options, output settings and output B.
- 26) The threshold can be set according to any combination of RPM and pressure set points.
- 27) Connect the vacuum line to intake manifold vacuum.
- 28) Reconnect the battery.

FTC1-115D Fuel/Timing Calibrator for 2.7L Toyota 3RZ

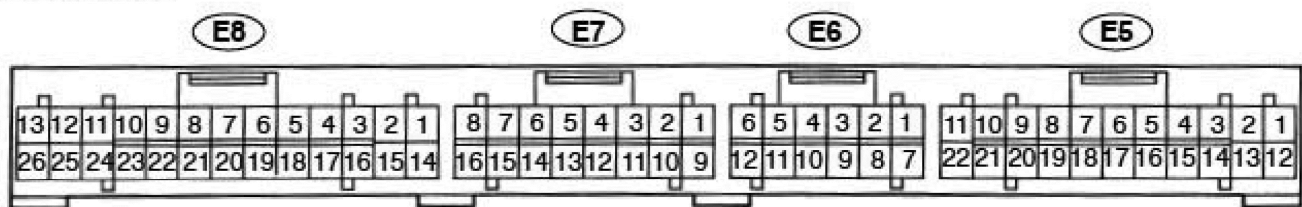

Use and Installation Instructions (ECU Referenced to 2000 Non-CA 3RZ-FE Tacoma):

- 1) Disconnect the battery before making connections to the factory wiring harness.
- 2) Use solder and heat shrink for the best possible electrical connections.
- 3) The following wires are in the main wire group.
- 4) Connect the **RED** wire (B+) to the WHITE/RED wire on ECU pin E5-12.
- 5) Connect the **BLACK** wire (B-) to the BROWN wire on ECU pin E8-13.
- 6) Connect the **BLACK/YELLOW** wire (tach) to the BLACK/YELLOW wire on ECU pin E8-17.
- 7) Cut the RED (crank sensor) wire leading to ECU pin E6-12.
- 8) Connect the **GREEN** wire to the cut wire leading to the crank sensor.
- 9) Connect the **GREEN/RED** wire to the cut wire leading to the ECU crank sensor input.
- 10) Cut the YELLOW (cam sensor) wire leading to ECU pin E6-11.
- 11) Connect the **BLUE** wire to the cut wire leading to the cam sensor.
- 12) Connect the **BLUE/WHITE** wire to the cut wire leading to the ECU cam sensor input.
- 13) Cut the WHITE (OX1) wire leading to ECU pin E7-5.
- 15) Connect the **PINK** wire to the cut wire leading to the sensor.
- 16) Connect the **PINK/BLUE** wire to the cut wire leading to the OX1 ECU input.
- 17) Cut the BLACK (OX2) wire leading to ECU pin E7-13.
- 18) Connect the **WHITE** wire to the cut wire leading to the sensor.
- 19) Connect the **WHITE/GREEN** wire to the cut wire leading to the OX2 ECU input.
- 20) Connect the **RED** and **TAN** wires in the small wire group to the corresponding wires on the injector harness.
- 21) If you would like to control an external load with the R4 software connect the **ORANGE** wire as follows.
- 22) Connect the **ORANGE** relay driver wire to the negative side of the relay coil.
- 23) Connect the coil positive to a fused B+ circuit.
- 24) Switch the load through the relay contacts.
- 25) Set up the turn-on threshold for the relay under options, output settings and output B.
- 26) The threshold can be set according to any combination of RPM and pressure set points.
- 27) Connect the vacuum line to intake manifold vacuum.
- 28) Reconnect the battery.

FTC1-115D Fuel/Timing Calibrator for 2.4L Toyota 2RZ

ECM Terminals

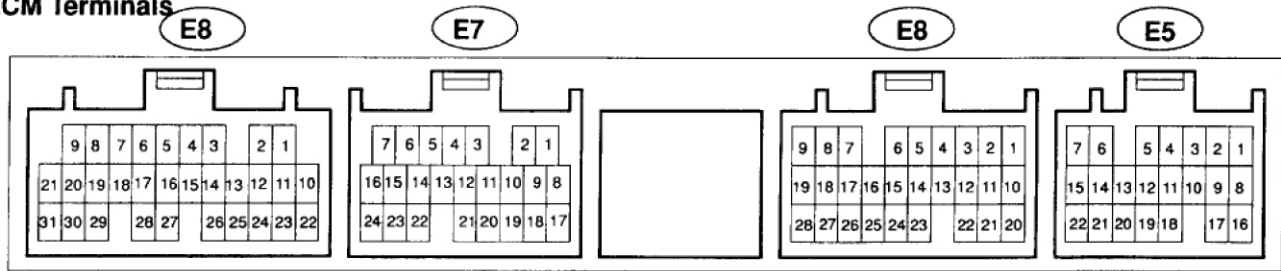

Use and Installation Inst (ECU referenced to 2001 thru 2004 2RZ-FE Tacoma):

- 1) Disconnect the battery before making connections to the factory wiring harness.
- 2) Use solder and heat shrink for the best possible electrical connections.
- 3) The following wires are in the main wire group.
- 4) Connect the **RED** wire (B+) to the **WHITE/RED** wire on ECU pin E5-16.
- 5) Connect the **BLACK** wire (B-) to the **BROWN** wire on ECU pin E7-17.
- 6) Connect the **BLACK/YELLOW** wire (tach) to the **BLACK/YELLOW** wire on ECU pin E8-10.
- 7) Cut the **BLUE** (crank sensor) wire leading to ECU pin E7-16.
- 8) Connect the **GREEN** wire to the cut wire leading to the crank sensor.
- 9) Connect the **GREEN/RED** wire to the cut wire leading to the ECU crank sensor input.
- 10) Cut the **RED** (cam sensor) wire leading to ECU pin E7-15.
- 11) Connect the **BLUE** wire to the cut wire leading to the cam sensor.
- 12) Connect the **BLUE/WHITE** wire to the cut wire leading to the ECU cam sensor input.
- 13) Connect the **PINK/BLUE** wire to the **VIOLET** wire on ECU pin E7-11.
- 14) The **PINK** wire is not used and can be left disconnected.
- 26) Cut the **BLACK** (OXS) wire leading to ECU pin E7-10.
- 27) Connect the **WHITE** wire to the cut wire leading to the sensor.
- 28) Connect the **WHITE/GREEN** wire to the cut wire leading to the OXS ECU input.
- 29) Connect the **RED** and **TAN** wires in the small wire group to the corresponding wires on the injector harness.
- 30) If you would like to control an external load with the R4 software connect the **ORANGE** wire as follows.
- 31) Connect the **ORANGE** relay driver wire to the negative side of the relay coil.
- 32) Connect the coil positive to a fused B+ circuit.
- 33) Switch the load through the relay contacts.
- 34) Set up the turn-on threshold for the relay under options, output settings and output B.
- 35) The threshold can be set according to any combination of RPM and pressure set points.
- 36) Connect the vacuum line to intake manifold vacuum.
- 37) Reconnect the battery.

FTC1-115D Fuel/Timing Calibrator for 2.7L Toyota" FN

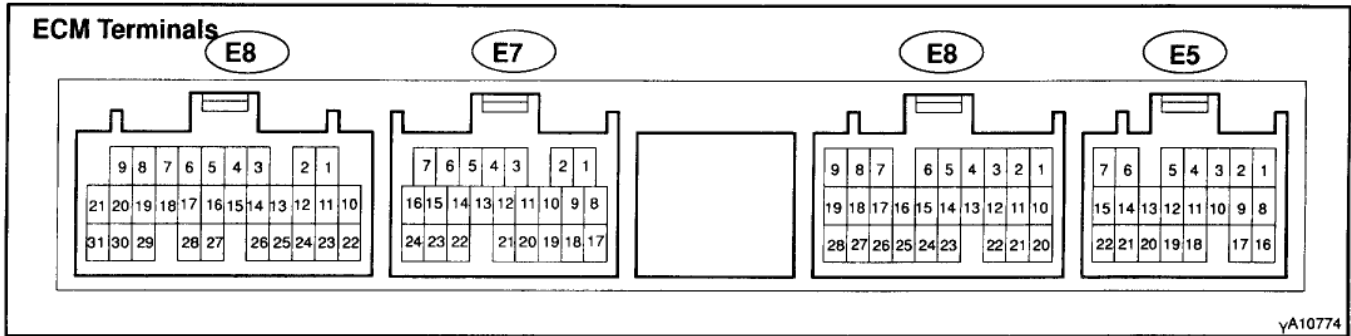

Use and Installation Instructions (ECU referenced to 2001 thru 2004 3RZ-FE Tacoma):

- 1) Disconnect the battery before making connections to the factory wiring harness.
- 2) Use solder and heat shrink for the best possible electrical connections.
- 3) The following wires are in the main wire group.
- 4) Connect the **RED** wire (B+) to the **WHITE/RED** wire on ECU pin E5-16.
- 5) Connect the **BLACK** wire (B-) to the **BROWN** wire on ECU pin E7-17.
- 6) Connect the **BLACK/YELLOW** wire (tach) to the **BLACK/YELLOW** wire on ECU pin E8-10.
- 7) Cut the **BLUE** (crank sensor) wire leading to ECU pin E7-16.
- 8) Connect the **GREEN** wire to the cut wire leading to the crank sensor.
- 9) Connect the **GREEN/RED** wire to the cut wire leading to the ECU crank sensor input.
- 10) Cut the **RED** (cam sensor) wire leading to ECU pin E7-15.
- 11) Connect the **BLUE** wire to the cut wire leading to the cam sensor.
- 12) Connect the **BLUE/WHITE** wire to the cut wire leading to the ECU cam sensor input.
- 13) Connect the **PINK/BLUE** wire to the **VIOLET (AF+)** wire on ECU pin E7-11
- 14) The **PINK** wire is not used and can be left disconnected
- 15) Cut the **BLACK (OXS)** wire leading to ECU pin E7-10
- 16) Connect the **WHITE** wire to the cut wire leading to the O2 sensor
- 17) Connect the **WHITE/GREEN** wire to the cut wire leading to the ECU O2 sensor input
- 18) Connect the **RED** and **TAN** wires in the small wire group to the corresponding wires on the injector harness
- 19) If you would like to control an external load with the R4 software connect the **ORANGE** wire as follows
 - 20) Connect the **ORANGE** relay driver wire to the negative side of the relay coil
 - 21) Connect the coil positive to a fused B+ circuit
 - 22) Switch the load through the relay contacts
 - 23) Set up the turn-on threshold for the relay under options, output settings and output B
 - 24) The threshold can be set according to any combination of RPM and pressure set points
 - 25) Connect the vacuum line to intake manifold vacuum
 - 26) Reconnect the battery

Trouble Shooting

Symptom	Possible Causes	Corrective Action
Idles rough, "pings" (Trouble Code PO171 Lean Code)	Lean condition-vacuum leak	Check vacuum line connections for leaks and cracked ends Review factory service manual for proper factory vacuum routing Review instructions for proper vacuum line routing Recheck torque on throttle body bolts Recheck the torque on the intake manifold bolts
Pings during acceleration	Low octane fuel Computer has yet to adjust to supercharger Insufficient fuel delivery	Use only premium fuel Drive several hundred miles in different driving modes (not all steady-state highway cruising for example) Dirty fuel Filter-replace and follow the factory diagnosis and replacement procedures
Low boost	Belt slipping Air filter dirty Throttle not fully opened	Check condition of belt, oily, worn, high mileage Check/replace air filter Recheck and adjust the throttle and transmission cables. Be sure that full depression on the gas pedal achieves full throttle opening at the throttle body.
Makes a moderately loud noise under full	Normal supercharger sound	No remedy. Superchargers are an air pump and the pumping action is impossible without some noise.
Rattling at idle goes away at just above idle	Normal supercharger sound	Slight rattle at idle is normal, but only if the noise sharply decreases at 400- 500 rpm above idle
Rattling at idle gets louder with higher rpm	Drive housing bearing wear or backlash Idler pulley bearing wear or excessive freeplay	Diagnose by removing belt from supercharger and running engine for less than 30 seconds. If noise continues. source of problem is not within supercharger
Supercharger belt jumps across pulley groove	Misaligned tensioner pulley or idler pulley Damaged pulleys	Check the mounting and alignment of both the tensioner pulley and also the idler pulley
Supercharger belt leaves grey/black powder	Normal break-in residue	No corrective action necessary-belt should be fully broken in after 2000 miles
Supercharger appears to leak oil from drive	Front seal not fully broken in	No immediate corrective action is necessary seal should be fully mated to pulley after 2000 miles.